

Thank you for purchasing this Dynojet kit. This kit has been developed for a motorcycle which is set to the parameters listed at the right in the "Stage" description. If your motorcycle does not meet any of these parameters please check with Dynojet before installation. For technical assistance contact your Dynojet distributor or call Dynojet U.S.A. (800)-992-4993

2191 Mendenhall Dr. Suite 105
 North Las Vegas, NV 89031
 TEL: 702-399-1423
 FAX: 702-399-1431
 8am-5pm Pacific Time
 Monday through Friday

Website Address
<http://www.dynojet.com>

The manufacturer and seller make no warranties express or implied which extend beyond the description of the goods contained herein. Any description of this product is for the purpose of identifying it and shall not be deemed to create an express warranty.



E1135.002

European Models Only

1989-90 Honda CBR600

Stage 1&2

STAGE 1

For mildly tuned machines using the stock airbox, with stock or K&N filter #HA-6087

STAGE 2

For mildly tuned machines using individual filters or velocity stacks. K&N filters #HA-6087

Both stages may be used with a good aftermarket exhaust.

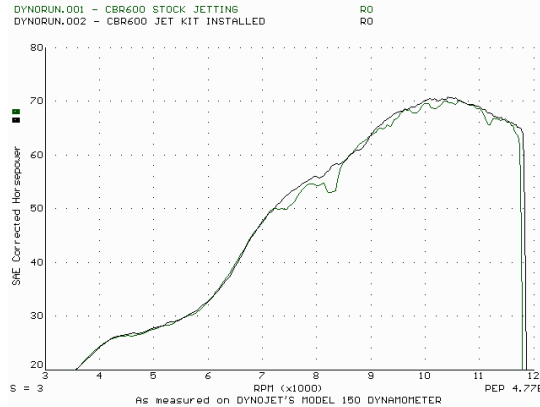

This graph shows a typical gain with a Dynojet jet kit.

WARNING

**NO SMOKING!
 NO OPEN FLAME!
 WHILE INSTALLING
 YOUR DYNOJET KIT**

Parts List

4	Main Jets	DJ098
4	Main Jets	DJ102
4	Main Jets	DJ120
4	Main Jets	DJ124
1	Slide Drill	DD #30
1	Slide Drill	DD #37
4	Fuel Needles	DNO129
4	Adjusting Washers	DW0001
4	E-Clips	DE0001
1	Insert	DIF22

STAGE ONE INSTRUCTIONS

1. Remove vacuum slide from carbs. Remove stock needles & spacers, noting order of assembly. Using the slide drill provided, DD# 37 (the 30 drill bit may be used to drill the slide for racing or hard street riding) drill your slide lift holes (Fig. A), the picture may not show your slide exactly. Drill your existing slide lift holes only, do not drill any new holes and do not drill the needle hole.
2. Install Dynojet needles on groove #3, using all stock spacers (Fig. A). Install the Dynojet washer above the E-clip.
3. Remove the main jet and replace with the Dynojet main jets provided. Use DJ098 with stock exhaust pipe, or use DJ102 with aftermarket header or slip-on with high flowing baffles. Be sure that the jet you are changing is the main jet.
4. Locate the Fuel Mixture Tab (Fig. B). Remove the float bowls and file off the stop tabs nearest to the adjusting tabs on the float bowl, this will allow for easier adjustment. Carefully turn mixture tabs clockwise until seated, then back out 2-1/2 turns.

Fig. A

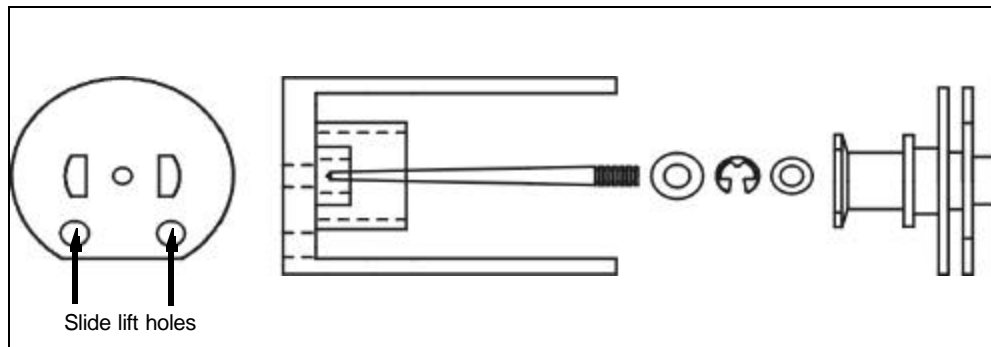

STAGE TWO INSTRUCTIONS

1. Remove vacuum slide from carbs. Remove stock needles & spacers, noting order of assembly. Using the slide drill provided, DD# 37 (the 30 drill bit may be used to drill the slide for racing or hard street riding) drill your slide lift holes (Fig. A), the picture may not show your slide exactly. Drill your existing slide lift holes only, do not drill any new holes and do not drill the needle hole.
2. Install Dynojet needles on groove #4, using all stock spacers (Fig. A). Install the Dynojet washer above the E-clip.
3. Remove the main jet and replace with the Dynojet main jets provided. Use DJ120 with stock exhaust pipe, or use DJ124 with aftermarket header or slip-on with high flowing baffles. Be sure that the jet you are changing is the main jet.
4. Locate the Fuel Mixture Tab (Fig. B). Remove the float bowls and file off the tabs nearest to the screw on the float bowl, this will allow for easier adjustment. Carefully turn mixture tabs clockwise until seated, then back out 2-1/2 turns.

Fig. B

