

Thank you for purchasing this Dynojet kit. This kit has been developed for a motorcycle which is set to the parameters listed at the right in the "Stage" description. If your motorcycle does not meet any of these parameters please check with Dynojet before installation. For technical assistance contact your Dynojet distributor or call Dynojet U.S.A. (800)-992-4993



E1138.002

European Models Only

1989-90 Honda XL600 Transalp

Stage 1

For mildly tuned machines using the stock air-box, with stock or K&N filter# HA-6089. May also be used with a good aftermarket exhaust system.

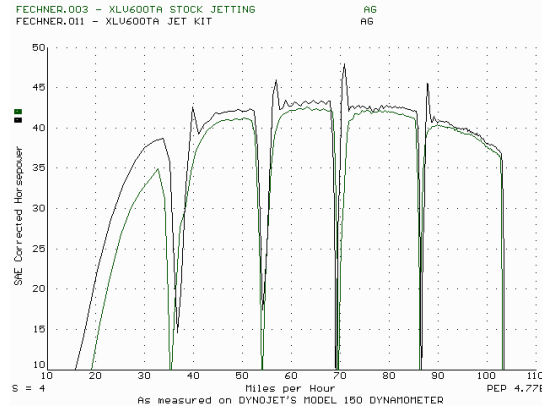

This graph shows a typical gain with a Dynojet jet kit.

WARNING

**NO SMOKING!
 NO OPEN FLAME!
 WHILE INSTALLING
 YOUR DYNोजET KIT**

2191 Mendenhall Dr. Suite 105
 North Las Vegas, NV 89031
 TEL: 702-399-1423
 FAX: 702-399-1431
 8am-5pm Pacific Time
 Monday through Friday

Website Address
<http://www.dynojet.com>

The manufacturer and seller make no warranties express or implied which extend beyond the description of the goods contained herein. Any description of this product is for the purpose of identifying it and shall not be deemed to create an express warranty.

Parts List

2	Main Jets	DJ124
2	Main Jets	DJ128
2	Main Jets	DJ134
1	Slide Drill	DD #5/32
2	Fuel Needles	DNO112
2	Adjusting Washers	DW0001
2	E-Clips	DE0001

STAGE ONE INSTRUCTIONS

DYNOJET
E1138.002

1. Remove the vacuum slide from the carbs. Remove the stock needles & spacers, noting order of assembly. Locate the slide lift holes using Fig. A, with the slide drill (DD #5/32) supplied, enlarge your slide lift holes. The picture may not show your slide exactly, enlarge your slide lift hole or holes depending on your model. Do not drill any new lift holes. Do not drill the needle hole.
2. Install the Dynojet needles on groove #4, using all stock spacers. Install the Dynojet washers above the E-clip.
3. Remove stock main jets and replace with Dynojet main jets provided. If you are running the stock exhaust use the DJ124 main jets, if you are running an aftermarket header or slip-on with high flowing baffle, use the DJ128 main jets. Be sure that the jets you are changing are the main jets.
4. Locate the Fuel Mixture Screw (Fig. B). Carefully turn mixture screws clockwise until lightly seated, turn out 2-1/2 turns.

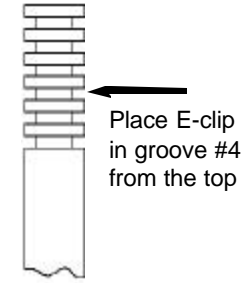

Fig. A

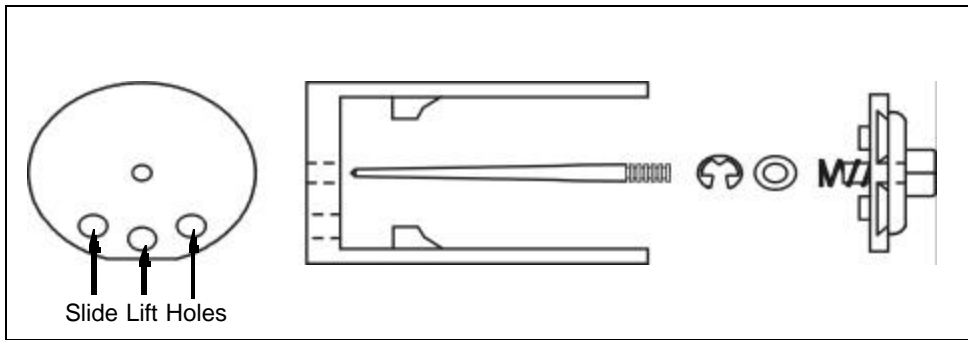

Fig. B

