

Thank you for purchasing this Dynojet kit. This kit has been developed for a motorcycle which is set to the parameters listed at the right in the "Stage" description. If your motorcycle does not meet any of these parameters please check with Dynojet before installation. For technical assistance contact your Dynojet distributor or call Dynojet U.S.A. (800)-992-4993



E4141.002

European Models Only

1993-94 Yamaha YZF750

Stage 1

For mildly tuned machines using the stock airbox, with stock or K&N filter. May also be used with a good aftermarket exhaust system.
K&N filter #YA-0081

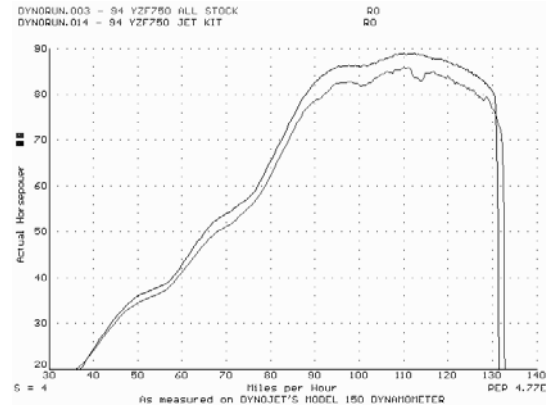

This graph shows a typical gain with a Dynojet jet kit.

WARNING

**NO SMOKING!
NO OPEN FLAME!
WHILE INSTALLING
YOUR DYNOJET KIT**

2191 Mendenhall Dr. Suite 105
North Las Vegas, NV 89081
TEL: 702-399-1423
FAX: 702-399-1431
8am-5pm Pacific Time
Monday through Friday

Website Address
<http://www.dynojet.com>

The manufacturer and seller make no warranties express or implied which extend beyond the description of the goods contained herein. Any description of this product is for the purpose of identifying it and shall not be deemed to create an express warranty.

Parts List

4	Main Jets	YJ120
4	Main Jets	YJ124
4	Main Jets	YJ128
12	Main Jet O-Rings	YJ-0
4	Fuel Needles	DNO356A
4	Main Air Plugs	DCO400
4	E-clip	DE0001
4	Adjusting Washer	DW0001
1	Glue	DA0001

STAGE ONE INSTRUCTIONS

1. Remove the vacuum slide from the carbs. Remove the stock needles & spacers, noting order of assembly.
2. Install the Dynojet needles on groove #4, using all stock spacers (Fig. A). Install the Dynojet washer above the E-clip.
3. Remove the main jets and replace with the Dynojet main jets provided. Use the YJ120 main jets with stock exhaust pipe, or use the YJ124 main jets with aftermarket header or slip-on with high flowing baffles. Be sure that the jets you are changing are the main jets.
4. Locate the fuel mixture screw (Fig. B), Carefully turn the mixture screw clockwise until lightly seated, then back out 2-1/2 turns.
5. Locate the main air correctors (Fig. C), using the plugs provided (DCO400) plug the main air passage. Place the plug in the carb flat end first. Tap in lightly. A touch of super glue (DA0001) will hold corrector in place.

Dynojet
E4141.002

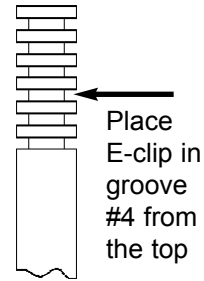

Fig. C

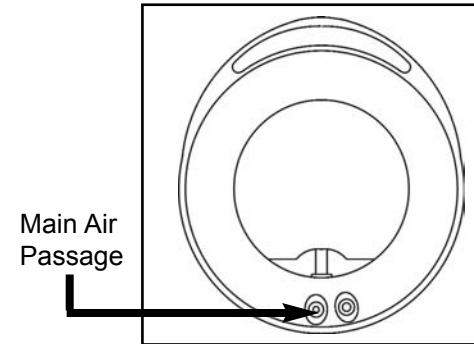

Fig. A

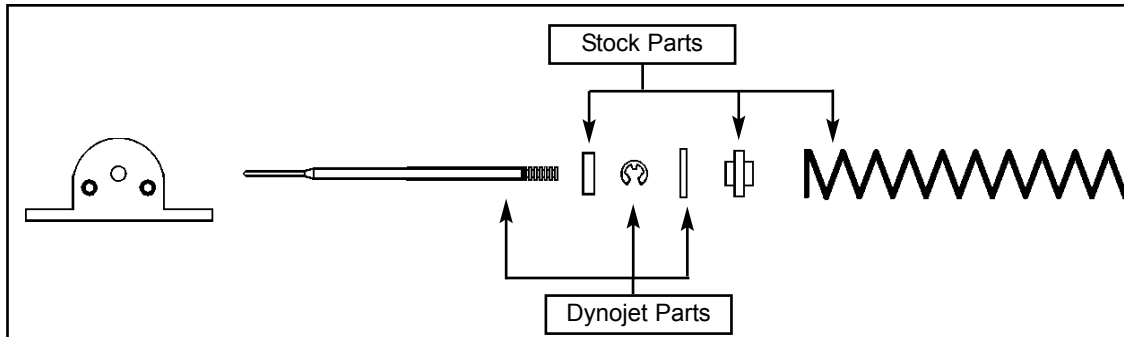

Fig. B

